

Irrigation



Irrigation

BERMAD Irrigation

Irrigation



BERMAD Irrigation

Solenoid Valves

S - Series

Water Control Solutions





Company Profile

Experience and proven results have made BERMAD synonymous with water and other fluid control and management. Cutting-edge technology is one of the reasons BERMAD has retained its reputation for excellence over the past 30 years. Now, entering the 21st century, BERMAD — an ISO 9002 certified company, is actively involved in fluid control and management systems encompassing a wide variety of applications, including:

- Municipal waterworks
- High-rise buildings
- Industrial systems
- Irrigation systems in:
 - Agricultural
 - Turf (golf courses)
 - Home gardening
- Cooling systems
- Fire protection systems
- Petroleum systems



BERMAD - continues to develop, manufacture and market a wide range of fluid control and management products that are sought, sold and serviced in nearly every country and every language. These products include:

- Automatic control valves
- Water meters
- Automatic metering valves
- Hydrometers
- Solenoid pilot valves
- Air valves

BERMAD sells know-how together with products. Its team of international and local experts is available everywhere for consultation and for training - in seminars and in the field - of engineers, technicians, sales staff and end users.

Product design and verification, high-performance advanced materials and equipment, and the latest CAD/CAM technology are implemented at BERMAD with the aid of advanced Enterprise Resource Planning.

BERMAD products are supported at all times by application engineers, service personnel and spare parts inventories, which ensure reliable and long lived performance. BERMAD's quality control staff is made up of experienced, highly qualified employees.

All BERMAD products are rigidly tested for proper operation under various pressure and flow rate conditions.

A significant share of the company's revenues is invested in Research and Development. BERMAD's R&D department specializes in creating new and innovative products that provide solutions to customer and market needs.





Contents

	Page
■ Company Profile	
■ Product Introduction	1
■ Continuous Current Solenoid Pilot Valves	
□ Model S-390: 2-way Solenoid Pilot Valve	3
□ Model S-390/S-200: 3-way Solenoid Pilot Valve	4
■ Magnetic Latch (Pulse) Solenoid Pilot Valves	
□ Model S-392: 2-way, Magnetic Latch Solenoid Pilot Valve	6
□ Model S-202: 3-way, Magnetic Latch Solenoid Pilot Valve	7
□ Models S-982 and S-985: 3-way, Magnetic Latch Solenoid Pilot Valves	8
■ Typical Applications	
□ 200 Series Valves	9
□ Remote Terminal Unit (RTU)	11
□ Solenoid Pilot Valves Mounted on Common Manifold for Sequential Operation	12

Product Introduction

Today, many newly installed irrigation systems are controlled by electric irrigation controllers, both direct and wireless. Existing systems are being upgraded so that they will be operated by computer and controller. The controller sends electric commands. An interface device that can convert the electric commands from the controller to a hydraulic activity for the irrigation equipment is needed. A solenoid pilot valve functions as this interface device.

The solenoid pilot valve, upon receiving an electric signal from the controller, converts the signal into motion of a plunger (a small piston), which in turn opens an orifice through which water can pass into or from the control mechanism of the valve.

Principle Product Description:

BERMAD's S-Series Solenoid Pilot Valves are sold as either a solenoid alone or as an assembled solenoid with hydraulic base/body. The assembly is then referred to as a solenoid pilot valve. BERMAD will provide each customer (according to their request) the solenoid either with or without the hydraulic base/body as an integrated unit.

Each solenoid base can be equipped with a 2 or 3-position manual override, enabling external control.



Product Introduction

Cut-Away and Components

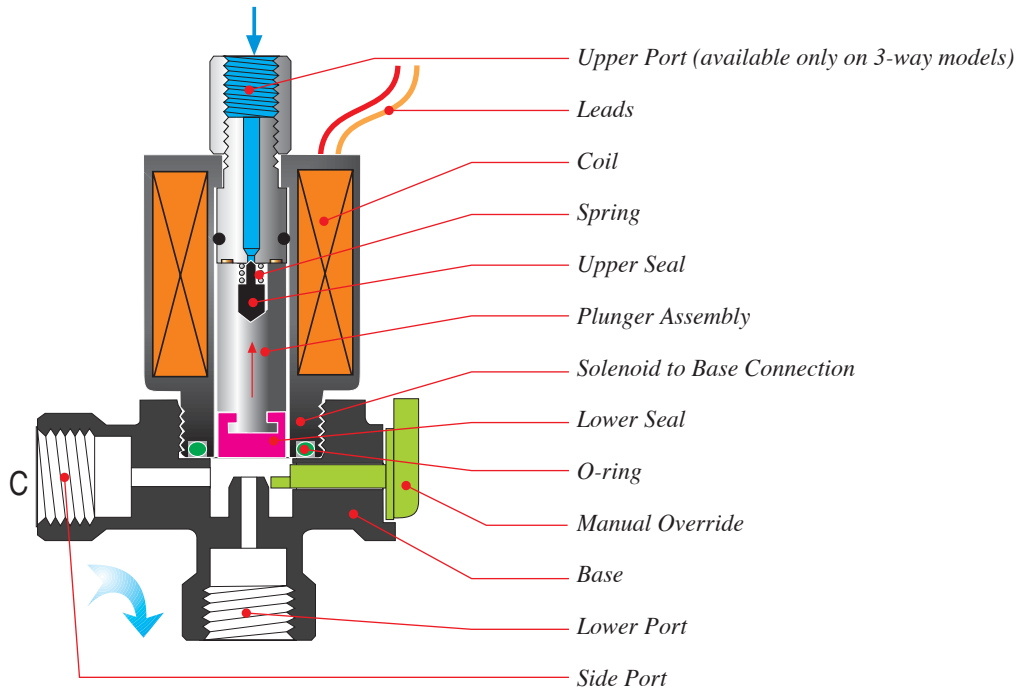

Notes:

1. Throughout this catalog you will find references to solenoid pilot valves being either energized or de-energized, and valves being either open or closed. Any combination of the two states of the two units can occur.
2. In 3-way solenoid pilot valves, the two ports, Pressure (P) and Exhaust (Ex) can be either at the upper or lower ports according to the application.
3. To ensure compatibility of a specific solenoid pilot valve with your system, please contact BERMAD's local representative.

Continuous Current Solenoid Pilot Valves

BERMAD's continuous current solenoid pilot valves are suited for general purpose horticultural, turf and gardening irrigation systems. They are built for either direct installation on irrigation valves (3/4"-4" as part of a valve control loop for irrigation applications) or on a separate hydraulic base (1/8" plastic or 1/8", 1/4" metal). The solenoid valve excels in its small overall outside dimensions, advanced operation and high reliability.

Magnetic Latch (Pulse) Solenoid Pilot Valves

BERMAD's S-392 (2-way, 3-wire), S-202 (3-way, 2-wire), S-982 (3-way, 2-wire) and S-985 (3-way, 3-wire), magnetic latch solenoid pilot valves are typically used in areas where reliable electrical power is not readily available or continuous current is not desirable. They require minimal electric power and can be operated using low power batteries as the electrical power source. A recent additional use is prepayment systems.

BERMAD's magnetic latching solenoids have two stable operating positions: latched and released (unlatched). Electrical power is not required to hold the plunger in either of these positions. A momentary electrical pulse causes the plunger to change positions from latched to released and vice versa.



Continuous Current Solenoid Pilot Valves

Model S-390: 2-way Solenoid Pilot Valve

Technical Data and Specifications:

- **Pressure Range:** 0-10 bar
- **Materials:**
 - Seals: NBR
 - Wet parts: Stainless steel 400 and nylon
- **Base Flow Factor:** Kv = 1.3 l/min at ΔP of 1 bar with orifice size 1.8 mm
- **Solenoid to Base Connection:** 3/4" 20 UNEF threaded
- **Leads:** 0.32 mm² x 30 cm

Operating Principle

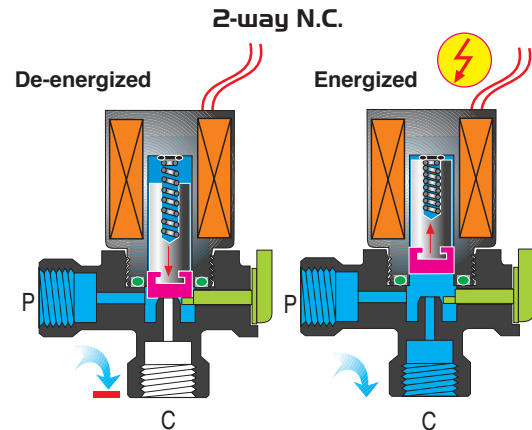

2Way Electrical Data

Actuator Type	Actuator Index	Cable Color	Power (watt)	Current (amp)		Coil Resistance ohm@20°C
				Inrush	Holding	
24VAC-R	AR	Red	1.7	0.28	0.14	35
24VAC-D	ED	Red/Orange	2.2	0.13	0.13	56
24VAC-R	DR	Red	2.2	0.76	0.43	6
24VDC	AO	Black	3.6	0.15	0.15	170
12VDC	HO	Blue	3.8	0.17	0.17	38

Maximum cable length according to coil type (at cable cross section: 0.5 mm², orifice size: 1.8 mm, air gap: 0.8 mm)

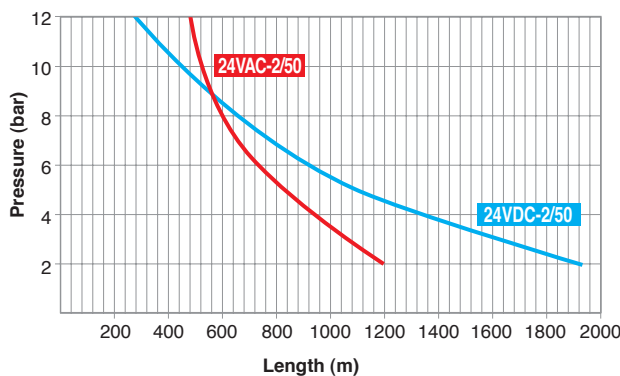

For cables longer than shown in diagram...

In order to calculate the cross section of a length other than shown in the diagram, use the following equation:

$$S = \frac{L(\text{sol})}{L(\text{diagram})} \times 0.5$$

S = Minimum conductor cross-section in mm²

L (sol) = Length of actual cable to solenoid

L (diagram) = Length of cable shown in this diagram



Continuous Current Solenoid Pilot Valves

Model S-390: 3-way Solenoid Pilot Valve

Technical Data and Specifications:

- **Pressure Range:** See Flow Data table on page 5
- **Materials:**
 - Seals: NBR
 - Wet parts: Stainless steel 400 and nylon
- **Solenoid to Base Connection:** 3/4" 20 UNEF threaded
- **Leads:** 0.32mm² x 80cm
- **Upper Port Connection:** 1/8" NPT



Plastic base port: 1/8" NPT
Orifice diameter: 1.2, 1.6, 1.8 mm



Brass base port: 1/4" BSP
Orifice diameter: 2, 2.5, 3 mm

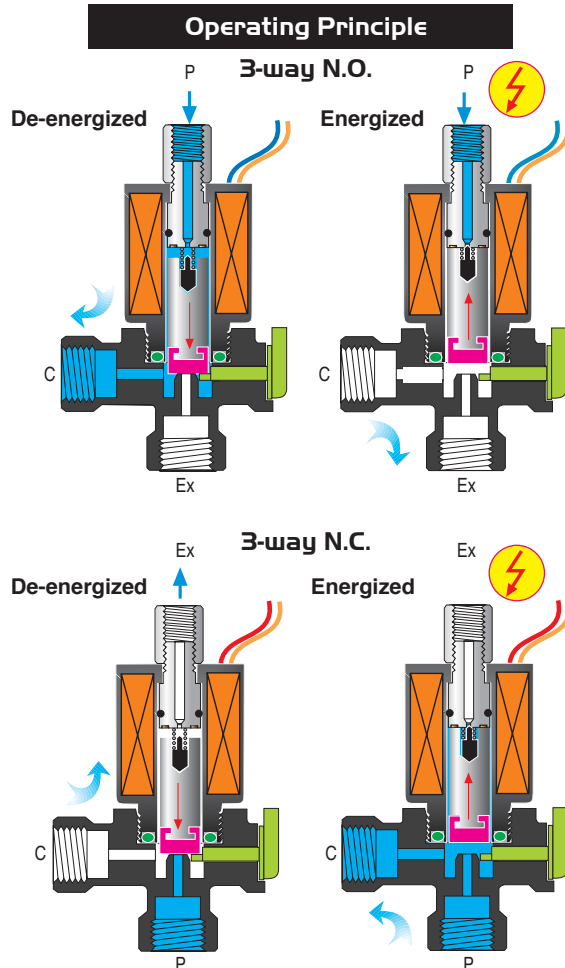

Maximum cable length according to coil type (at cable cross sectional area 0.5 mm², orifice size 1.8 mm, air gap 0.8 mm) for standard N.O. 3-way solenoids

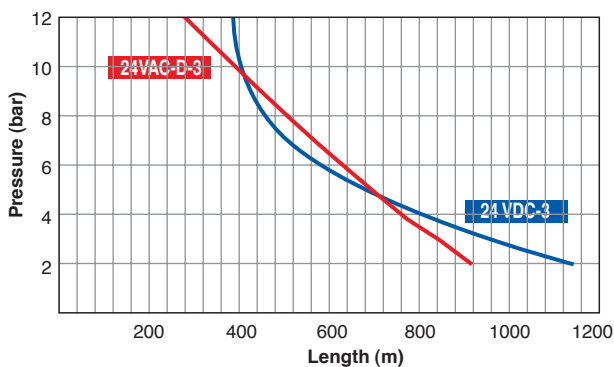

For cables longer than shown in diagram...

In order to calculate the cross section of a length other than shown in the diagram, use the following equation:

$$S = \frac{L(\text{sol})}{L(\text{diagram})} \times 0.5$$

- S = Minimum conductor cross-section in mm²
- L (sol) = Length of actual cable to solenoid
- L (diagram) = Length of cable shown in this diagram



Continuous Current Solenoid Pilot Valves

Model S-200: 3-way Solenoid Pilot Valve

The S200 is comprised of two main components: a solenoid and a 3-way hydraulic pilot valve.

The solenoid's 3-position, manual override enables external control. Changing the position of the manual lever on the solenoid and returning it to "Auto" position returns the solenoid to control by the actuator.

Specifications

Physical:

- **Materials:** Seals - NBR, Parts in contact with fluid - Nylon
- **Hydraulic Outlets:** 1/8" NPT
- **Valve Anchoring:** By Screw (Self Tapping #8) at the Solenoid base

Electrical Connections:

- **Leads:** 2 x 0.32 mm² x 80 cm

3 Way Electrical Data:

Actuator Type	Actuator Index	Cable Color	Power (Watt)	Current (Amp)		Coil Resistance
				Inrush	Holding	
S390 24VAC-D-NC	BD	Orange/Blue	3.5	0.20	0.20	*
S390 24VDC-NC	BO	Black	4.2	0.17	0.17	135
S390 12VDC-NC	CO	Blue	3.8	0.32	0.32	38
S390 24VAC-D-NO	AD	Red/Orange	2.2	0.13	0.13	*
S390 24VAC-R-NO	BR	Red	2.9	0.46	0.24	21
S200 24VAC-D-NO	CD	Red/Blue	3.5	0.20	0.20	*
S200 24VAC-R-NO	CR	Red	2.9	0.46	0.24	21
S200 24VAC-D-NC	DD	Red/Blue	3.5	0.20	0.20	*
S200 24VAC-R-NC	ER	Red	2.9	0.46	0.24	21
S390 24VDC-NO	DO	Black	4.2	0.17	0.17	135
S390 12VDC-NO	GO	Blue	3.8	0.32	0.32	38
S200 24VDC-NO	EO	Black	4.2	0.17	0.17	135
S200 12VDC-NO	FO	Blue	3.8	0.32	0.32	38

* Coil resistance in these coils cannot be measured



3 Way Flow & Pressure Data:

Actuator Type	Actuator Index	Pressure Rating (bar)			Inlet Port Kv (l/min)			Exhaust Kv (l/min)			Orifice Size (mm)
		1.6	1.8	2.2	1.6	1.8	2.2	1.6	1.8	2.2	
S390 24VAC-D-NC	BD	15	10		1.2	2.0		0.9			
S390 24VDC-NC	BO	10	5		1.2	2.0		0.9			
S390 12VDC-NC	CO	10	5		1.2	2.0		0.9			
S390 24VAC-R-NO	BR	10			0.9				2.0		
S390 24VAC-D-NO	AD	10			0.9				2.0		
S200 24VAC-D-NO	CD			10			2.0		2.0		
S200 24VAC-R-NO	CR			10			2.0		2.0		
S200 24VAC-D-NC	DD			10			2.0		2.0		
S200 24VAC-R-NC	ER		10				2.0			2.0	
S390 24VDC-NO	DO	8			0.9		2.0		2.0		
S390 12VDC-NO	GO	8			0.9				2.0		
S200 24VDC-NO	EO			10			2.0		2.0		
S200 12VDC-NO	FO			10			2.0		2.0		



Magnetic Latch (Pulse) Solenoid Pilot Valves

Model S-392: 2-way Magnetic Latch Solenoid Pilot Valve

Specifications

Physical:

Materials:

- Seals: NBR
- Wetted parts: Stainless steel 400 and polyamide

■ **Solenoid to Base Connection:** 3/4" 20 UNEF threaded

■ **Leads:** 2 leads x 0.32 mm² x 80 cm²

Operating:

■ **Pressure Range:** 0-10 bar

■ **Base Orifice:** Ø1.8 mm

■ **Base Flow Factor (Kv) =** 1.3 l/min

Electrical Data:

■ **Voltage Range:** 6-20 VDC

■ **Coil Resistance:** 6Ω

■ **Coil Inductance:** 90 mH

■ **Pulse Width:** 20-100 ms

Operation Modes (electrical connections)

- + **Red** & - **Black**: Latch Position
- + **Black** & - **Red**: Released Position

Note: To ensure compatibility of solenoid with your system, please contact BERMAD's local representative.



Operating Principle

N.C. Valve 2-way Latch Solenoid Operation

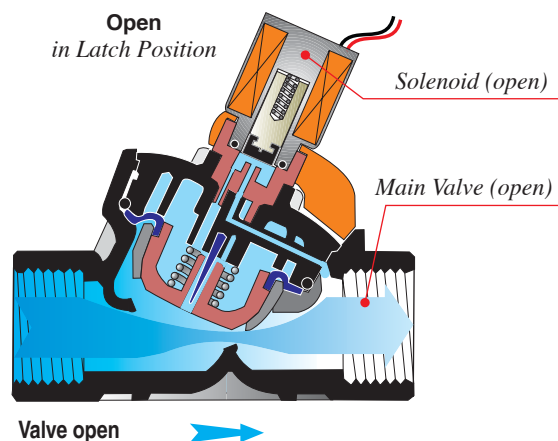



Magnetic Latch (Pulse) Solenoid Pilot Valves

Model S-202: 3-way, Latching Solenoid Pilot Valve

The S202 (2-wire) magnetic latch solenoid pilot valves are 2-position electrically operated valves. They are comprised of two main components: a solenoid and a 3-way hydraulic pilot valve.

The solenoid's 3-position, manual override enables external control. Changing the position of the manual lever of the solenoid and returning it to "Auto" position leaves the solenoid in its last position until another pulse is received.

Specifications

Physical:

■ Materials:

Seals - NBR, Parts in contact with fluid - Nylon

Hydraulic Outlets: 1/8" NPT

Valve Anchoring: By Screw (Self Tapping #8) at the Solenoid base

Operating:

- **Pressure Range:** 0-10 bar
- **Base Flow Factor:** (Kv.)
 - Pressure Port: 2.0 l/min.
 - Exhaust Port: 2.0 l/min.

Electrical:

- **Voltage Range:** 9-40 VDC
- **Pulse Width:** 20-100 mSec.
- **Coil Resistance:** 6Ω
- **Coil Inductance:** 90 mH

Operating Modes (electrical connections)

- **Leads:** 2 x 0.32 mm² x 80 cm
- **+Red & -Black:** solenoid vents.
- **+Black & -Red:** solenoid pressurizes.

Cable is black PVC sheathed.

Note: To ensure compatibility of solenoid with your system, please contact BERMAD's local representative.





Continuous Current Solenoid Pilot Valves

Models S-982 and S-985: 3-way, Magnetic Latch Solenoid Pilot Valves

The S-982 (2-wire) and S-985 (3-wire) magnetic latching solenoid pilot valves are 2-position, electrically operated valves. All models are comprised of two main components:

- Water isolated actuator
- 3-way hydraulic pilot valve

The solenoid's 3-position manual override enables external control. The manual lever however does not affect the electrically controlled actuator position. Thus, when the manual lever is returned to "AUTO" position, the solenoid maintains its most recent position until another pulse is received. At that point the solenoid continues to function normally.

Specifications

Physical:

- Materials: Seals - NBR, Parts in contact with fluid - Nylon
- Hydraulic Outlets: 1/8" NPT
- Valve Anchoring: By screws (Self Tapping #8) at the Solenoid base

Operating:

- Pressure Range: 0-10 bar
- Orifice size: Ø2.2 mm
- Base Flow Factor Kv:
 - Pressure Port: 2.0 l/min.
 - Exhaust Port: 2.3 l/min.

Electrical:

- Voltage Range: 12-50 VDC
- Pulse Width: 20-100 ms
- Coil Resistance:
 - S-982: 1 Coil - 4.2Ω
 - S-985: 2 Coils - 4.2Ω: On, 7.5Ω: Off



Operating Modes (electrical connections)

Model S-982: 2-wire, 3-way, Magnetic Latch Solenoid Pilot Valve:

Leads: 2 x 0.32 mm² x 80 cm

- + **Red** & - **Black**: solenoid vents
- + **Black** & - **Red**: solenoid pressurizes

Model S-985: 3-wire, 3-way, Magnetic Latch Solenoid Pilot Valve:

Leads: 3 x 0.32 mm² x 80 cm

- + **White**: Fixed common
- - **Red**: solenoid vents.
- - **Black**: solenoid pressurizes.

Cable is black PVC sheathed.

Note: To ensure compatibility of solenoid with your system, please contact BERMAD's local representative.



Typical Applications

200 Series, Globe Pattern

Description

A 3/4" or 1", Globe pattern, main hydraulic valve is directly operated by an S-390 2-way solenoid. These solenoid pilot valves are typically used in irrigation systems for turf, public and private gardens, greenhouses and small plots.



Valve Configuration

A

N.C. Valve
(2-way Solenoid Operated)

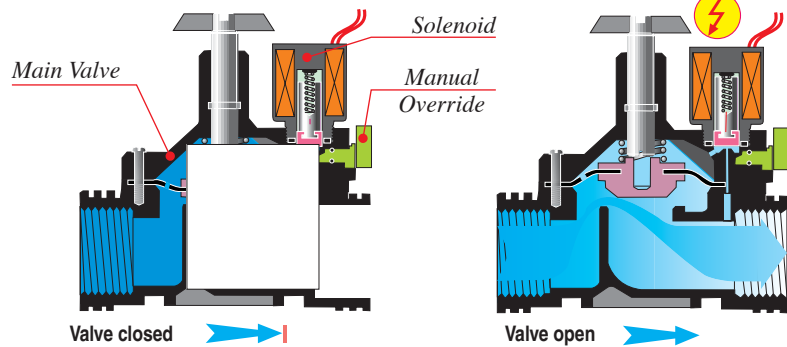

B

N.C. Valve
(3-way N.O. Solenoid Operated)
Designed for debris laden water.

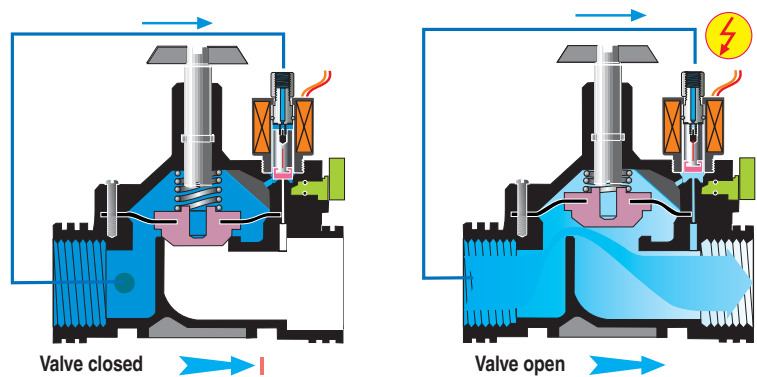

C

N.O. Valve
(3-way N.C. Solenoid Operated)





Typical Applications

200 Series, Globe Pattern

Electrically Operated Valve

In this typical application, an external 3-way solenoid is added to a 1 1/2 or 2' hydraulic valve, creating an electrically operated hydraulic valve.

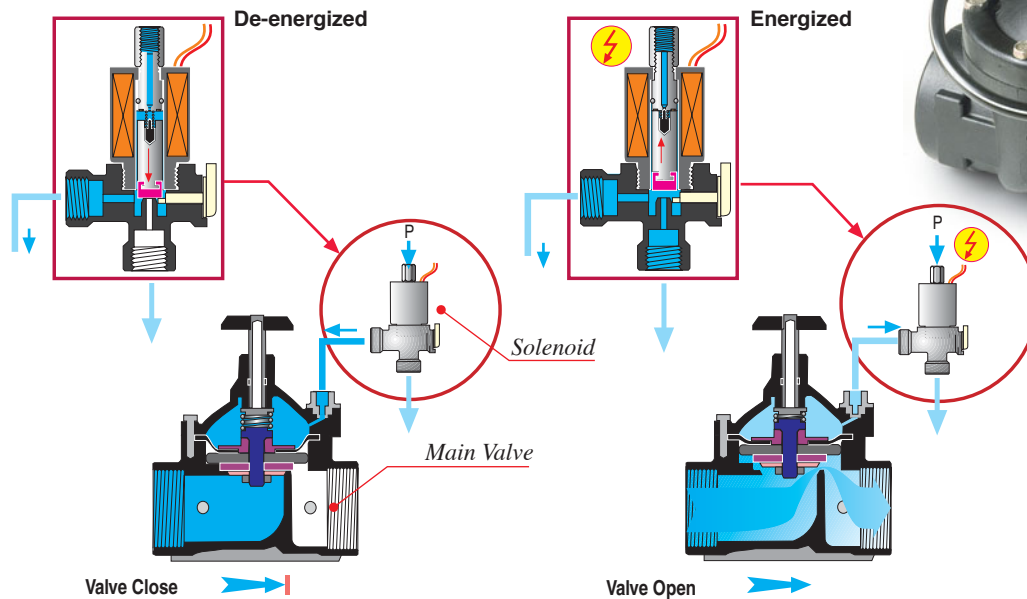

200 Series, "Y" Pattern

Description

Available as 3/4" or 1" Y-pattern, main hydraulic valve directly operated by an S-390 2-way solenoid.

For debris laden water or applications where fast response is needed, a 3-way solenoid pilot valve connected to an external pressure source is also available.

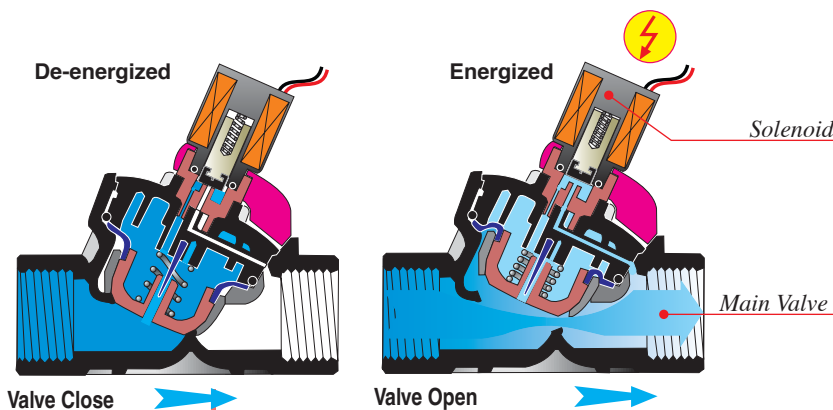



Typical Applications

Solenoid Valve for RTU

BERMAD's Solenoid Valve for Remote Terminal Unit (RTU) is a solenoid pilot valve controller used in radio or cable remote control irrigation. It is a battery operated, self-contained unit. This solenoid pilot valve is suitable for use in irrigation applications with a master radio control system. For instance, Motorola's Irrinet Terminal Unit transmits commands (by cable or radio) to an electronic card (located inside the black plastic cover) activating a BERMAD Model S982 or S985 Magnetic Latch Solenoid Valve.

Features

- Telemetry
- Battery Operated (for radio controlled units)
- Low Power Consumption
- Low Battery Detection
- Manual Override
- Current Sensing Detector
- Waterproof Housing
- Built-in Self-Diagnostic



Motorola IRRInet Controller

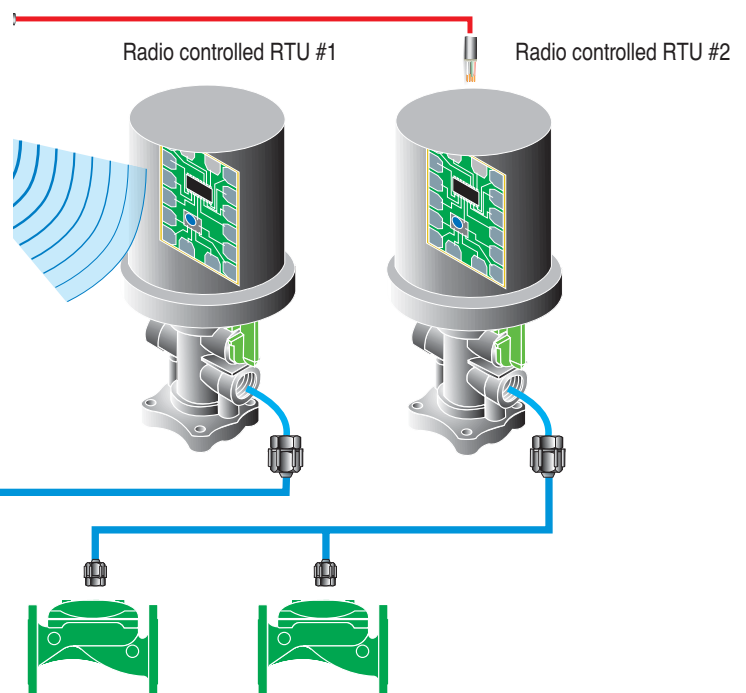

BERMAD Remote Terminal Units (RTU)



Typical Applications

Solenoid Pilot Valves Mounted on Common Manifold for Sequential Operation

Solenoid pilot valves provide the link between an irrigation controller and in-field hydraulic control valves.

A manifold arrangement provides centralization of all solenoid pilot valves near the controller, shortening the sometimes problematic electrical communication lines between the controller and the solenoids valves.

A command tube runs from each manifold-placed solenoid valve to the in-field hydraulic control valve(s).

Each solenoid valve can control multiple hydraulic control valves, depending upon limiting flow rate/available pressure.

Benefits:

- Lower cost of ownership (command tube run over long distances do not lose command pulse)
- Detection of problems is simpler (if there is leak or discontinuity the user can see it)
- Problem solving is simpler (water systems are considered more user-friendly than electrical systems)

This example illustrates a manifold constructed of DC operated magnetic latch solenoid pilot valves. Alternatively, a manifold can be assembled from continuous current solenoid

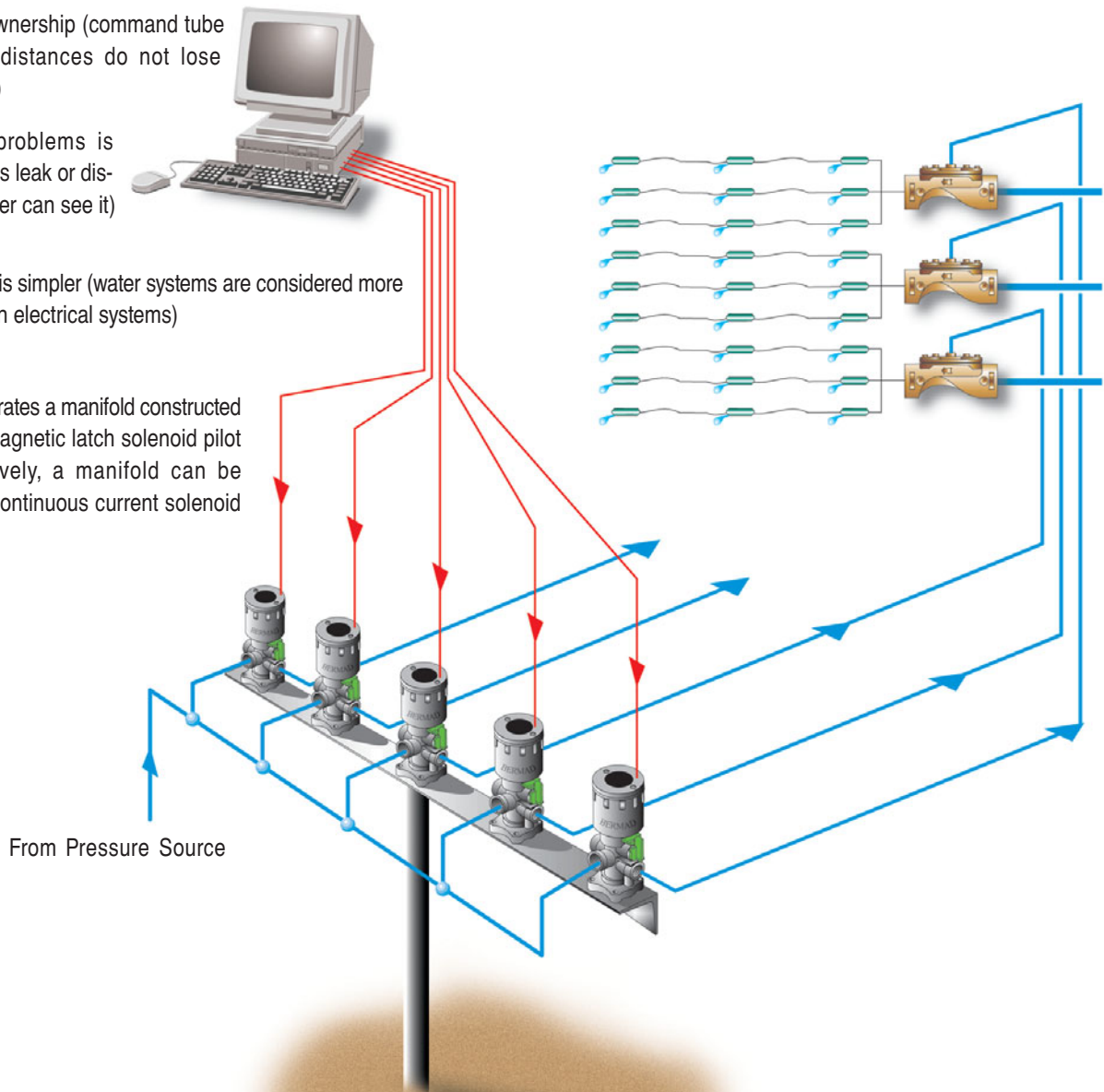

Irrigation

BERMAD Irrigation

Irrigation



BERMAD Irrigation

Irrigation

BERMAD

Water Control Solutions

BERMAD
Waterworks

BERMAD
Fire Protection

BERMAD
Petroleum

BERMAD
Agriculture

BERMAD
Gardening



info@bermad.com • www.bermad.com

The information contained in this document is subject to change without notice. BERMAD shall not be liable for any errors contained herein. All rights reserved.
© Copyright by BERMAD.

PCSXE01 04