

INTEGRATED ORIFICE

The Integrated Orifice can fulfil one or two main functions:

The Differential Integrated Orifice is used as part of a flow control valve's control circuit. Installed at upstream or downstream of the valve, it provides the differential pressure (ΔP) to power the flow control pilot. The opening and closing of the pilot causes the flow control valve to throttle accordingly. The Low Pressure sensing port is located close to the orifice's opening, sensing its downstream pressure before it recovers, thus helping to reduce total pressure loss across the flow control valve.

The Backpressure Integrated Orifice is installed at the downstream of a control valve, helping to protect it from cavitation damage and to reduce its operational load by increasing the valve's backpressure, as well as allowing a function of flow control when downstream pressure is constant.

The orifice internal diameter is calculated and machined according to valve size and required flow limitation at the required differential pressure (ΔP).

Technical Data

Material:

Standard: POM-C

Optional: SST 316

Sizes:

DN40-DN400; 1.5"-16"

Pressures rating:

40 bar; 600 psi

Sensing ports:

Differential: Upstream (HP) and Downstream (LP)

Backpressure: Downstream only

Size: Refer to Dimensions table

ΔP design:

Differential:

Default: 0.4 bar; 5.5 psi

Maximum: 2.0 bar; 29 psi

Backpressure:

Maximum: 10 bar; 145 psi

* Contact BERMAD for design and other ΔP

Approvals:

NSF Drinking Water:

POM-C: Up to 8"

SST 316: All sizes

Dimensions:

Size		O.D		I.D		Z		X	Y*
mm	Inch	mm	Inch			mm	Inch	NPT	mm
40	1.5"	73	2.9			22	0.9	1/8"	6
50	2"	94	3.7			22	0.9	1/8"	6
65	2.5"	106	4.2			22	0.9	1/8"	6
80	3"	130	5.1			22	0.9	1/8"	6
100	4"	155	6.1			22	0.9	1/8"	6
150	6"	210	8.3			22	0.9	1/8"	8
200	8"	263	10.4			22	0.9	1/8"	8
250	10"	318	12.5			27	1.1	1/4"	10
300	12"	370	14.6			27	1.1	1/4"	10
350	14"	416	16.4			27	1.1	1/4"	10
400	16"	480	18.9			32	1.3	1/4"	10

Calculated per required flow and DP (contact BERMAD for assistance)

* For easier installation insert lifting bolt

Differential Orifice

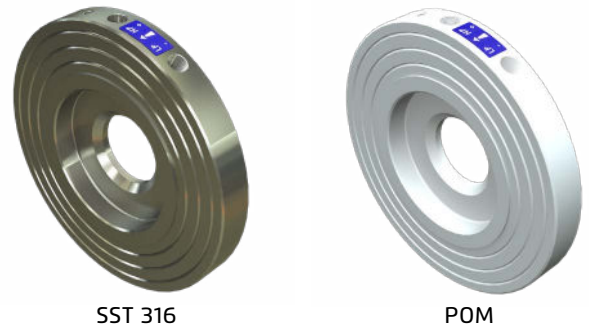

Backpressure Orifice



Differential Orifice

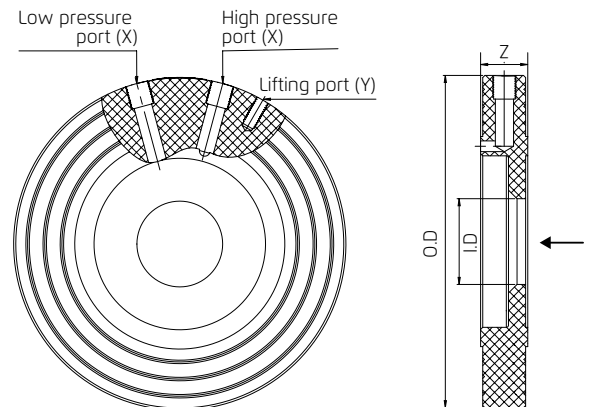

Backpressure Orifice

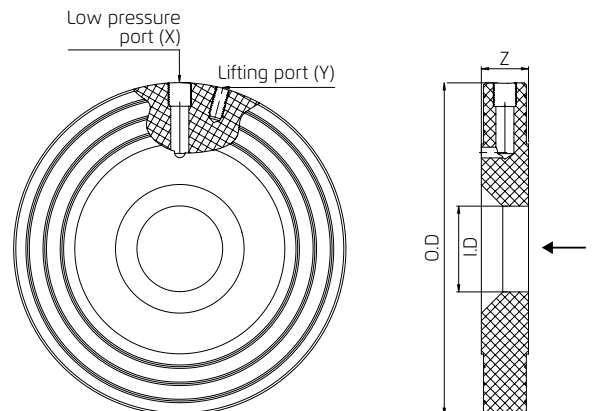

All images in this catalog are for illustration only



www.bermad.com

The information contained herein may be changed by BERMAD without notice. BERMAD shall not be held liable for any errors. April 2021

© Copyright 2011-2021 BERMAD CS Ltd.