

Installation and operation Manual

Bermad Surge Anticipation Valve

Model No 435



Valve Description

The model No 435 Surge Anticipation Valve is an off line , hydraulically operated diaphragm actuated control valve. The valve sensing the line pressure, opens in response to the pressure drop associated with the rapid pump stoppage. The pre opened valve dissipates the returning high pressure wave, eliminating the surge.

The model 435 closes drip tight as quickly as the relief feature allows, while preventing closing surge.

The valve also acts as a quick pressure relief valve responding to sudden increases in the line pressure.

Valve Technical Details

The following details relates to the technical specifications of the valve and components.

Basic Valve Type :	Bermad 400 series globe style hydraulic single chamber valve
Valve rating :	1600 Kpa max pressure 40Kpa minimum opening pressure
Valve material :	Epoxy coated cast iron with rubber diaphragm
Valve Model :	Model No IR-X-ASTE-435
Low Pressure Pilot :	#2 Bermad pilot with grub screw removed on port Z
Pressure rating :	1600Kpa maximum pressure
Spring range :	100-1250 Kpa adjustment
Rotation of bolt :	One rotation = 190Kpa approx
High Pressure Pilot :	#3 Bermad pilot
Pressure rating :	1600Kpa maximum pressure
Spring range :	100-1250 Kpa adjustment
Rotation of bolt :	One rotation = 190Kpa approx
Tubing :	3/8" copper with brass fittings (HP nylon optional)
Gauge :	0-1600Kpa dual scale 65mm liquid filled 1/4" BSP inlet

Installation and Sizing

We recommend the following installation considerations to ensure correct operation of the valve.

1. **Valve size.** We recommend that the valve size be discussed with the Bermad company for suitability of valve size for the application. In many instances there may be more than 1 valve in the operation should there be more than 1 pump in the network.
2. **Installation of valve position.** The best mode of installation is to have the valve horizontal, as it makes maintenance of the valve simpler and avoids any air pockets in the valve. Should the valve be fitted vertically, we suggest modifications to the valve cover to ensure best operation. We rotate the cover so that the connection to the cover is at the highest location.
3. **Installation of valve on pipeline.** The valve should be installed in accordance with the irrigation designer and Bermad valve recommendations. This will usually be located at the or close to the pump station after the check valves of the pump. The valves are usually mounted on a tee piece off the main pipeline itself.
4. **Installation of associated valves.** We recommend that a form of isolating valve (gate or butterfly) be mounted directly before the surge anticipation valve for reasons of setting or maintenance. In addition to this we recommend the use of an anti-slam air valve be mounted in the main pipeline to ensure there is no possibility of vacuum holding the valve closed on the down-surge. Again the irrigation designer with Bermad can recommend suitable valve sizing for the application. Bermad model C30-SP or Fox-AS should be considered.
5. **Discharge piping from surge valve.** The size of the pipe leaving the surge valve is critical to the safe operation of the valve. As the system velocity can be as high as 12-15m/s velocity, we suggest the pipe size is considerably larger than the valve size (in order to reduce system velocity) and the use of bends and elbows be kept to a minimum in order to reduce thrust on the pipework. The pipe must go to atmosphere and allow the surge to relieve without back pressure. If running pipe down a river bank, vacuum breakers (such as Bermad model 50mm C10) must be installed in order to avoid pipe collapse. This will also cause the valve to slam close which will also generate a secondary pipe surge.



Setting of the valve for operation

We suggest if there is any doubt in the operation or setting of the valve, you first contact your irrigation supplier or Bermad for assistance.

1. Ensure the pipeline is fully charged and the pipe is full as in normal operation.
2. Ensure you have a copy of the pump curve to identify the operation of the pumps.
3. Prior to opening the butterfly valve ensure the following is done to the Bermad 435 valve.
 - Open valve 1 and close valve 2
 - Turn adjustment bolt on low pressure pilot 2 anti-clockwise fully until there is no tension on the spring.
 - Turn adjustment bolt clockwise fully.
 - Turn needle valve on pilot #3 fully clockwise and tighten locknut.
 - Turn needle valve on pilot #2 clockwise fully and re-open $\frac{1}{4}$ of a turn.
4. Open the butterfly very slowly a small amount $\frac{1}{8}$ turn to apply pressure to the valve. When the pressure rises above 4m, the valve will open and as the chamber fills, the valve will start to close as water enters the control chamber. We suggest you carefully loosen a brass fitting on the copper tube to release the air from the top chamber of the valve. Once the valve has closed and all the milky water is gone, the valve is ready to be set.
5. The static pressure is now applied to the inlet side of the valve. Turn the low pressure pilot adjustment bolt clockwise slowly until water starts to vent out from the side of the pilot. The valve will start to open and will be limited as the butterfly valve is only $\frac{1}{8}$ th open. Turn the adjustment bolt slowly anti-clockwise until the water stops venting and the valve starts to close slowly. Once the valve is closed continue to turn the adjustment bolt anti-clockwise about 25% lower than the static pressure. For example if the static pressure is 400Kpa, turn bolt anti-clockwise $\frac{1}{2}$ of a turn. (remember 1 turn = 190Kpa).
6. Once the valve has closed, watch the pressure gauge to see that the valve did not close too fast. If the valve closed too fast, you can adjust the needle valve 21 on pilot #3. Turning clockwise to slow down. Anti-clockwise to speed up.
7. It is time now to set the high pressure relief pilot. What we like to do is have the valve open a small amount on pump start to relieve any upsurge. In some pump stations there may not be an upsurge if the soft start is sensitive to the system. When the pump starts, watch carefully to see how high the pressure goes and then what it settles to when the pump is running. When the pump is running, it is time to open valve 2 and set the pilot. Turn the adjustment bolt anti-clockwise slowly until water vents to the down stream. Turn the bolt then very slowly clockwise until the water stops venting.
8. It is now time to start and stop the pump several times to fine tune the settings of the pilots. The valve is now set.

Normal operation of the Surge Valve.

It is really important that the valve is always on line and ready to operate. Make sure the following are always open.

- **Inlet butterfly valve must be open.**
- **Inlet ball valve 1 and 2 must be open.**
- **Inlet filter must be clean**
- **Needle valve on #2 must not be blocked**

Drainage of the pipe.

It is really important to understand that should you decide to drain the pipe, the static pressure will drop and the surge valves will all burst open and start draining the system.

- **If you are going to drain the pipe, you must first isolate the surge valves to stop excessive speed on emptying of the pipe.**
- **Only re open the surge valves after the pipe has been re-charged.**
- **Ensure that the pipeline air release valves are all open and functioning as designed to avoid negative pressures in the pipeline**

Maintenance.

We suggest the following is carried out every year :

- Clean the inlet filter
- Flush all the water out of the control chamber of the 400 series basic valve.
- Check the inlet, outlet and bonnet connections to make sure there is no blockage in any ports.
- Close needle valve on the #2 pilot and re-open to the same set point.
- Check all control piping is in good condition and gauges are in good working order.
- Make sure the anti-slam air valve has been stripped and cleaned.
- Test function of the valves by starting and stopping the pumps.



BERMAD IR Spare Parts

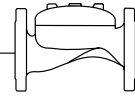

400 Series

Basic Control Valves For Irrigation (IR)

Sizes: 3/4"-10"; DN20-250

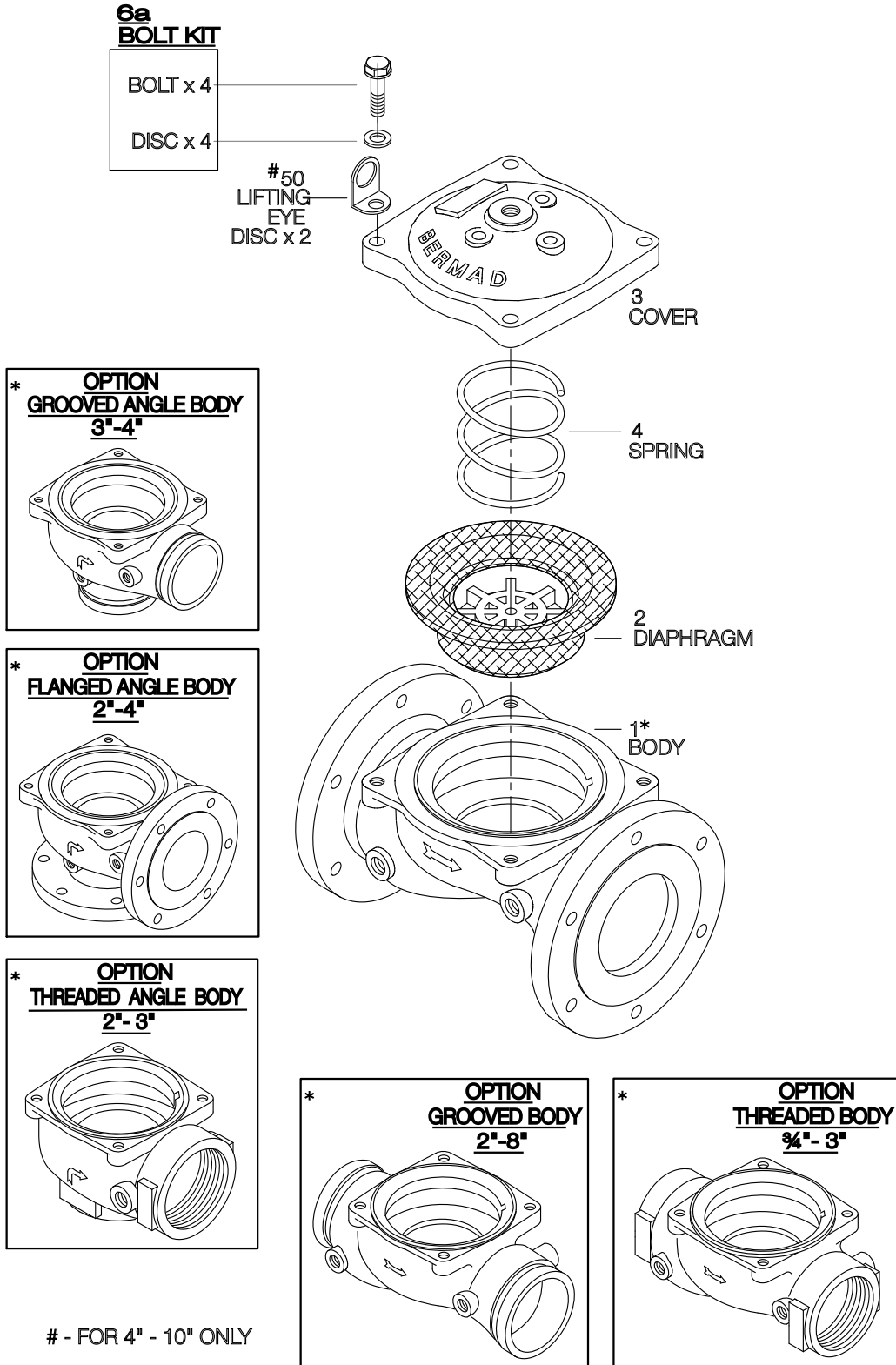

- FOR 4" - 10" ONLY



BERMAD IR Spare Parts

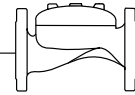

400 Series

Basic Control Valves For Gardening (LS)

Sizes: 3/4-2"; DN20-50

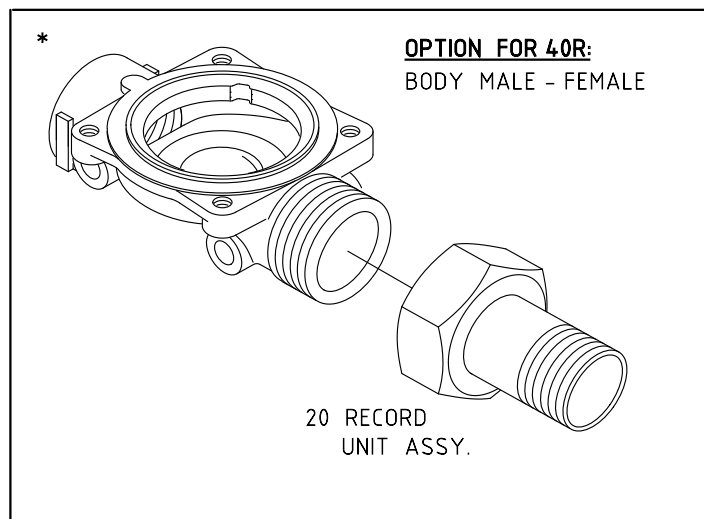
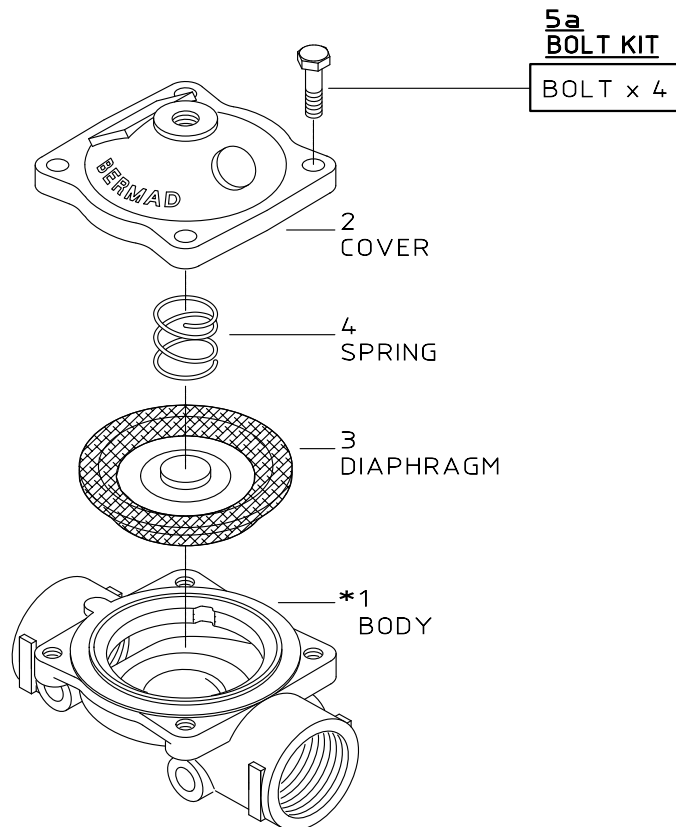

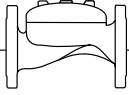

Basic Control Valves (IR & WW)

Sizes: 12-14"; DN300-350

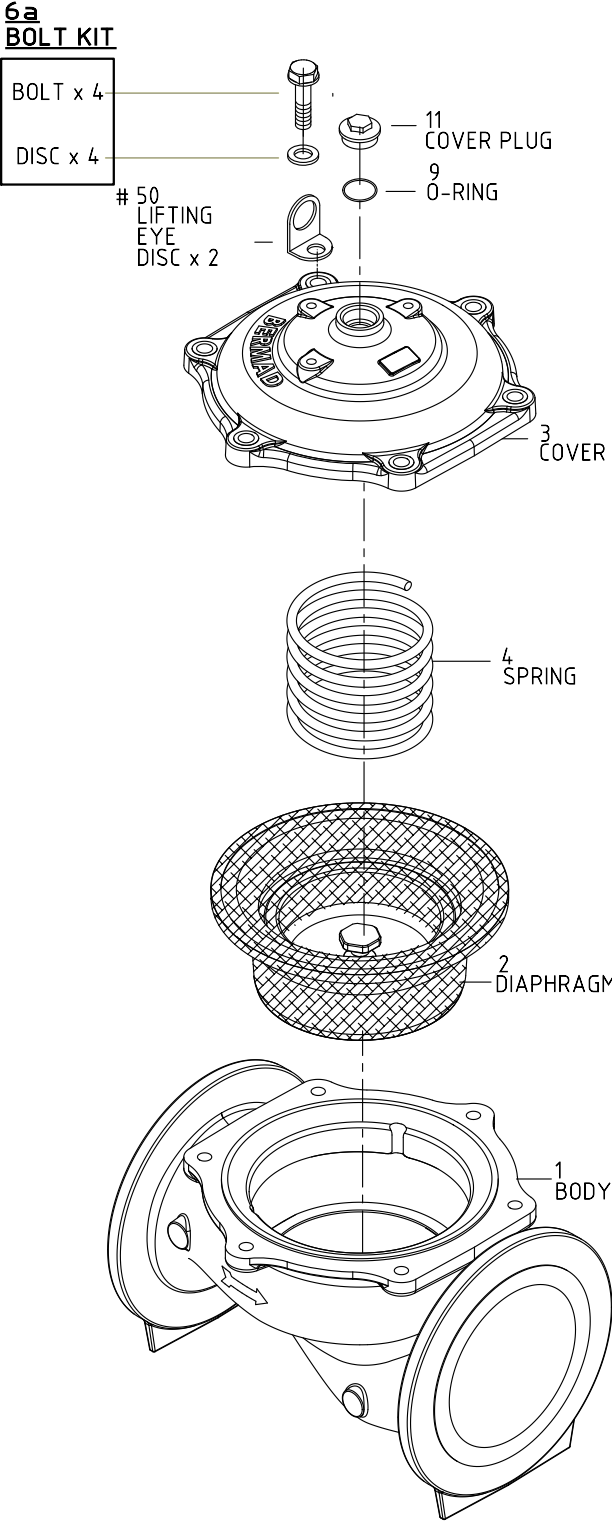



BERMAD IR Spare Parts

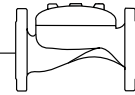

400 Series

Accessories

51
FLOW
STEM
ASSY.
2" - 10"

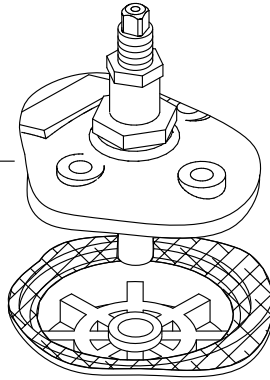

94
LIMIT
SWITCH
ASSY. 2" - 14" (SINGLE)

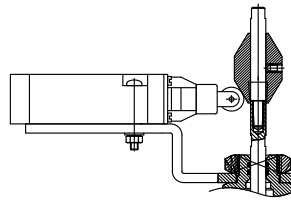

52
INDICATOR
ASSY.
2" - 3"

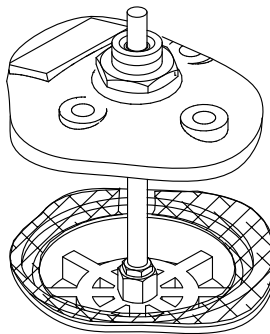

94
LIMIT
SWITCH
ASSY. 2" - 14" (DOUBLE)

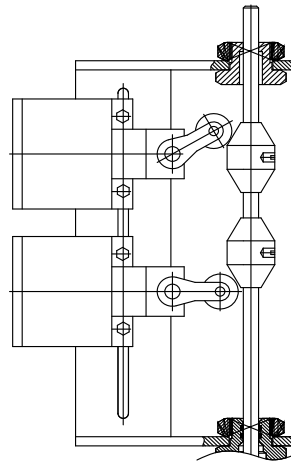

52
INDICATOR
ASSY.
4" - 14"

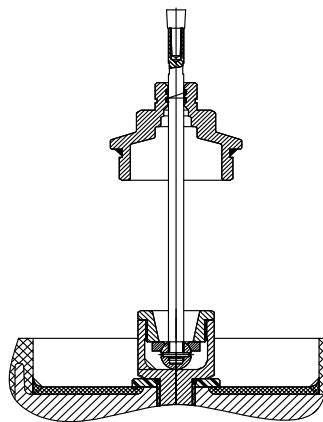



Large Control Filter

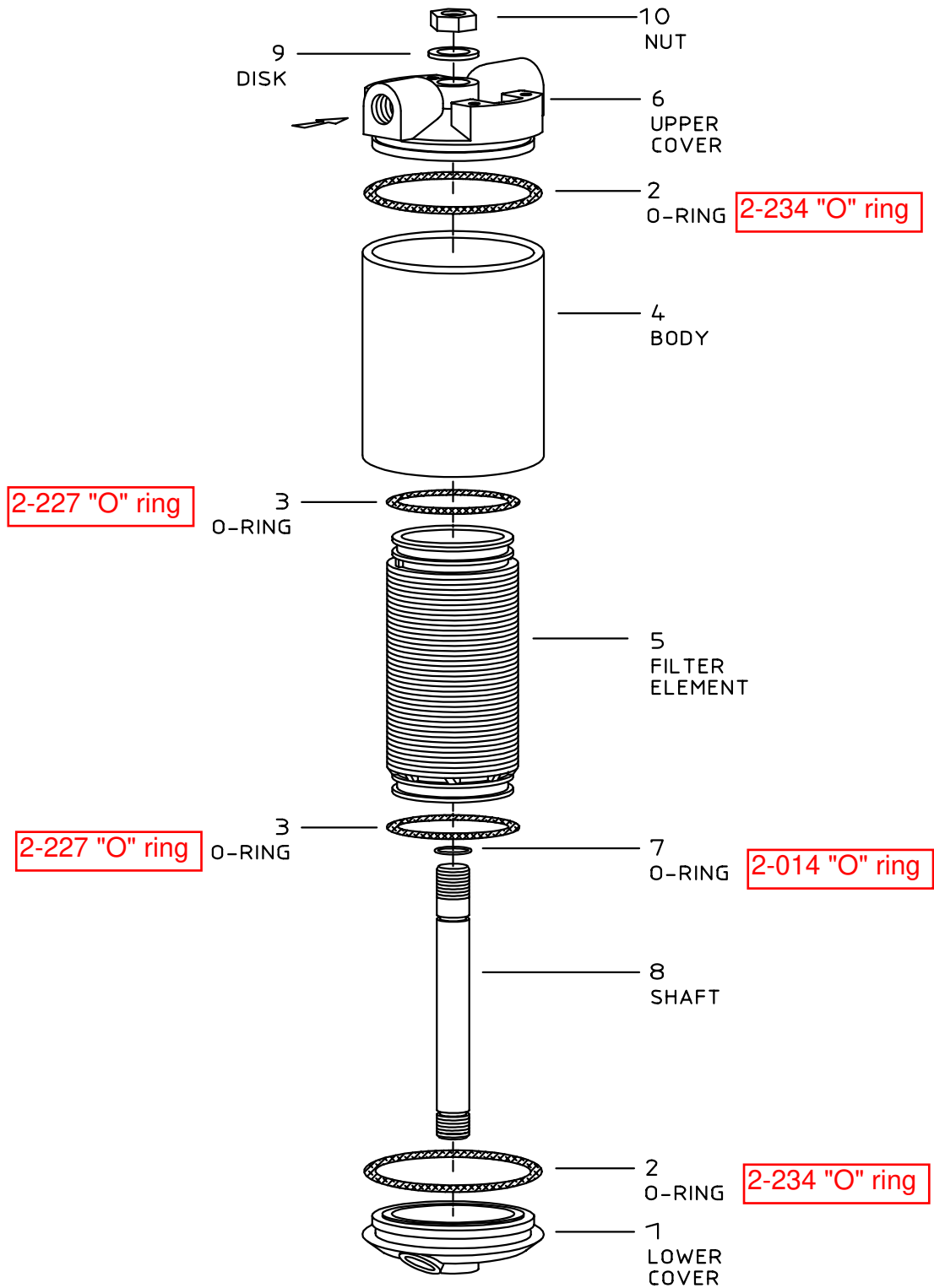

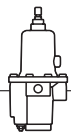

#3 2-way Pressure Sustaining Pilot Valve

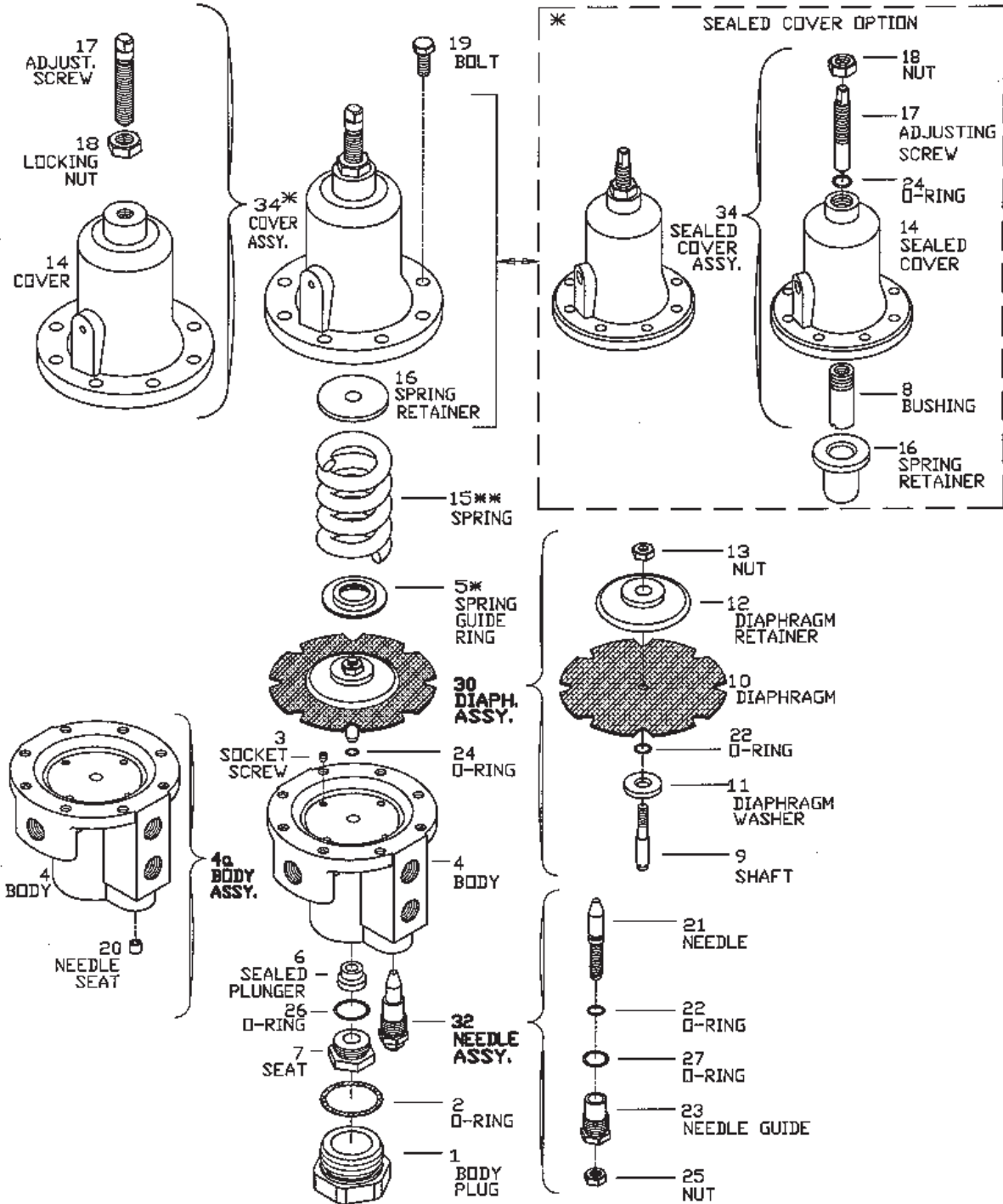

** - DIFFERENT SPRINGS

#2 2-way Pressure Reducing Pilot Valve

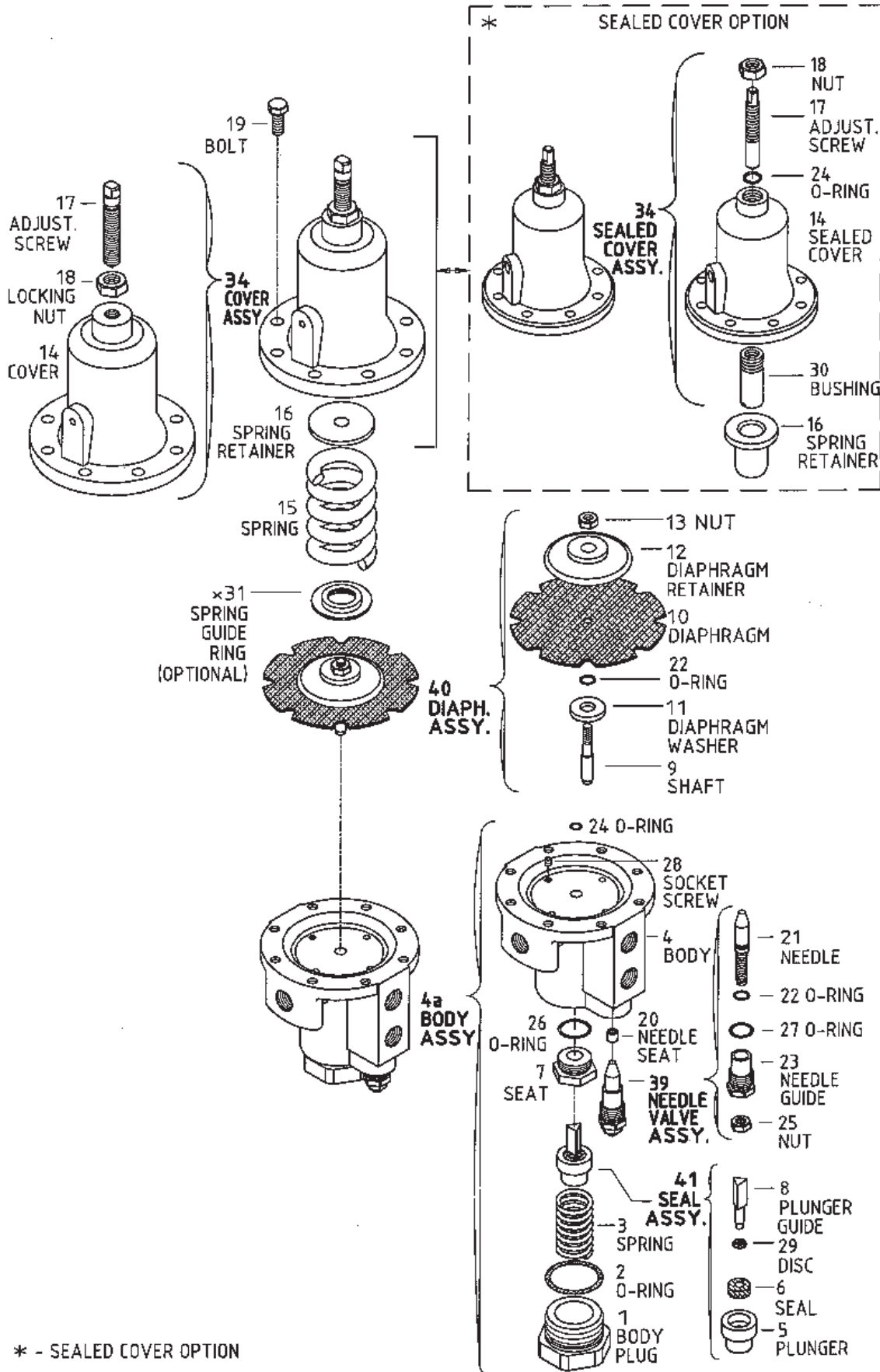

* - SEALED COVER OPTION