



Hydraulic Relay Valve (HRV-2)

The BERMAD HRV-2 is a pressure operated relay pilot valve used for release and opening of BERMAD deluge valves.

It is held closed by water or air pressure applied to its control chamber. Release of pressure from the control chamber opens the HRV-2 relay valve.

Materials

Body and Cover

- Nickel plated Brass
- Corrosion Resistance Options: Stainless Steel 316
Ni. Al. Bronze

Elastomers

- NBR

Wetted Parts

- Brass
- Corrosion Resistance Options: Stainless Steel 316
Ni. Al. Bronze

Technical Data

Orifice

- $\frac{3}{8}$ " (9 mm)

Pressure Rating

- 25 bar (365 psi)

Temperature

- Water up to 80°C (180°F)

Flow factor

- KV 1.3 (CV 1.5)

End Connections

- $\frac{3}{8}$ " NPT (F)w

Approvals

- UL-Listed ⁽¹⁾

Note:

(1) when installed on specific BERMAD Deluge valve



Brass Construction



Corrosion Resistant Construction
(for Illustration Only)

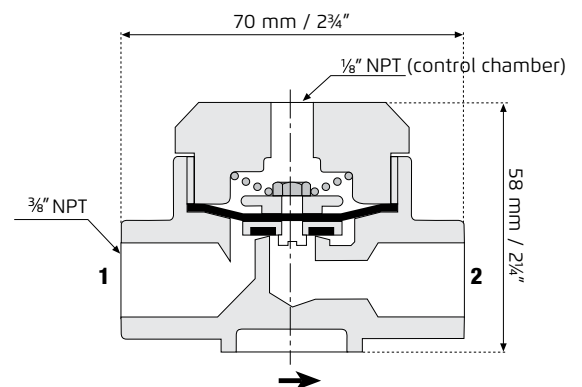

Weight (Brass): 0.6 Kg / 1.3 lbs.