

Double Interlock Pre-action, Electric-Pneumatic Release System

Model: FP 400E-7DM



Description

The BERMAD Model FP 400E-7DM Double Interlock Pre-Action, Electric-Pneumatic Release System is suitable for use in systems requiring that water be kept out of the sprinkler piping until an electric detecting device and a sprinkler have both been activated. Electric-Pneumatic Double Interlock Systems include automatic sprinklers attached to a dry sprinkler piping system, with a supplementary Electric Detection System and a Pneumatic Supervised System of low air pressure in the system piping. The Supervised System consists of a Pneumatic Pilot Valve (PORV), and pneumatic low pressure supply. The Double Interlock Pre-Action System admits water into the sprinkler piping only when the detection system triggers the solenoid valve through the control panel, while the PORV is simultaneously activated due to the pressure drop in the Supervised System.

An anti-flooding feature is provided by utilizing an in-line check valve, which creates an intermediate vented chamber using a Normally Open drip-check.

Typical Applications



Water damageable material storage:

- Computer & Electronics Rooms
- Libraries, Museums & Archives
- Telecommunications equipment
- Cable spreading rooms
- Oil-filled-transformer rooms



Freezing conditions

Features and Benefits

- **Latch open** - Closes only upon local reset
- **Factory pre-assembled trim** – Out-of box-quality
- **In-line serviceable** – Minimal down time
- **In-line Check Valve** – intermediate vented chamber- Anti flooding
- **One-piece molded elastomeric moving part** – No maintenance required

Optional Features

- **Air Maintenance Device (AMD)**
- **Water motor alarm**
- **Valve Position Single/Double Limit Switches**

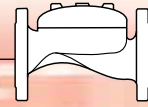

Operation

In the SET position, the line pressure supplied to the main valve's control chamber [1] via the priming line [2] and through an EasyLock Manual Reset [3], is trapped by the EasyLock internal check valve, by a closed Solenoid Valve [4] and by a closed Manual Emergency Release [5]. The trapped pressure holds the main valve's diaphragm and plug against the valve seat [6], sealing it bubble tight. The piping system is filled with monitored low air pressure to ensure all sprinklers [F] are sealed. An intermediate vented chamber is created by an in-line swing check valve [7], and a Normally Open drip-check [8].

In the event of FIRE, automatic sprinkler activation causes a pneumatic pressure drop that opens a Pneumatic Pilot Valve (PORV) [9] and activates air pressure switch low [10], while the main valve remains closed. Only when both the PORV and the Solenoid Valve open (triggered by the electric detection system [E], through a control panel [C]), pressure is released from the main valve's control chamber, through the opened Solenoid Valve and PORV (or the Manual Emergency Release). The EasyLock prevents line pressure from entering the control chamber, allowing the pre-action valve to latch open and water to flow into the system piping and to alarm device [11].

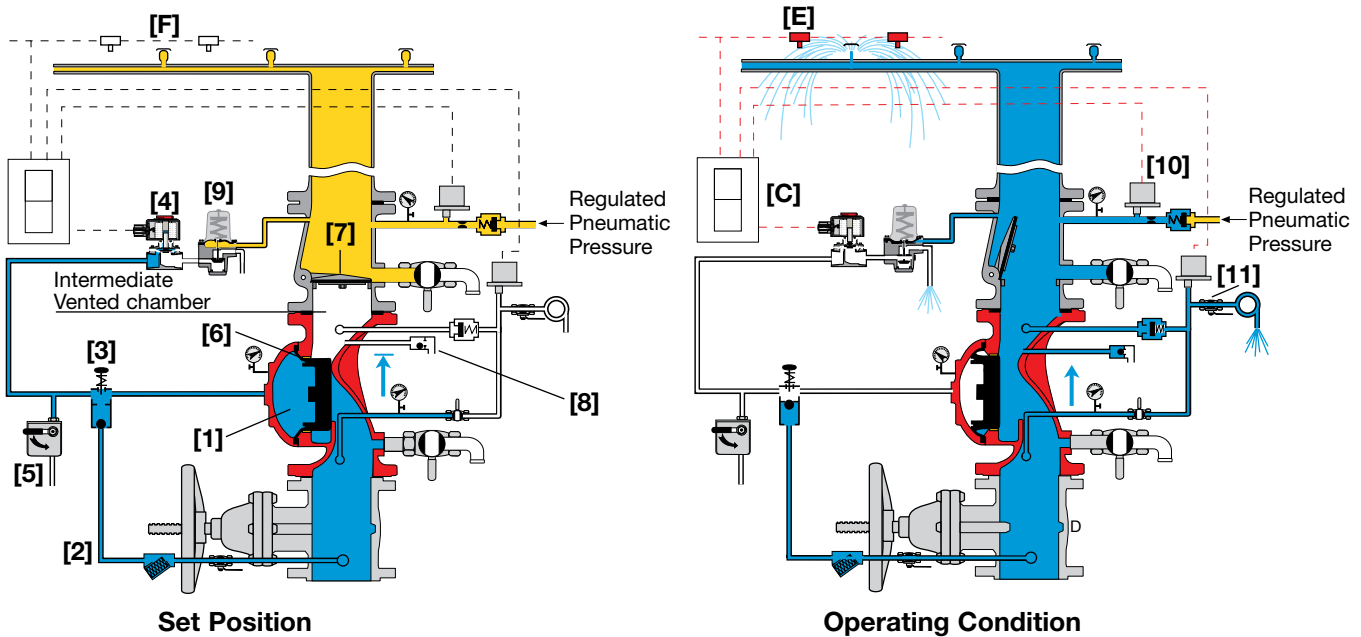

Engineer Specifications

- The pre-action valve shall be a UL-Listed, electrically-controlled elastomeric type globe valve with a **rolling-diaphragm**.
- The valve shall have an **unobstructed flow path**, with no stem guide or **supporting ribs**.
- Valve actuation shall be accomplished by a fully peripherally supported, one-piece balanced rolling-diaphragm, vulcanized with a rugged radial seal. The diaphragm assembly shall be the only moving part.
- The valve shall have a removable cover for quick in-line service enabling all necessary inspection and servicing.
- The control trim materials shall consist of St.St. 316 tubing and fittings, and plated brass accessories, including in-line swing check valve with resilient seal, local EasyLock Manual Reset, 2-Way Solenoid Pilot Valve, PORV pneumatic pilot valve, Y strainer, Automatic drip check with manual knob and Manual Emergency Release.
- The control trim shall be supplied as an assembly, pre-assembled and hydraulically tested at an ISO 9000 and 9001 certified factory.
- The Double Interlock Pre-action, Electric-Pneumatic Release System shall latch open in response to simultaneous activation of both the solenoid and a releasing device. The system shall reset to the closed position only upon local manual activation of the reset device.

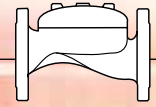

System Components

- 1 - Main Valve, BERMAD FP 400E Series
- 2A - Gauge Valve
- 3A - Pressure Gauge
- 4B - Priming Strainer
- 5A - Drain Valve
- 6B - Pneumatic Pressure Operated Relief Valve (PORV)
- 14B - Solenoid Valve
- 15B - Manual Emergency Release
- 18B - Priming Ball Valve
- 19B - Drip Check
- H - In-Line Swing Check Valve
- M - EasyLock Manual Reset
- P2 - Pressure Switch Low (PSL)
- Optional
- P - Pressure Switch High (PSH)

Regulated & Restricted
Pneumatic Pressure Supply



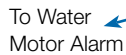
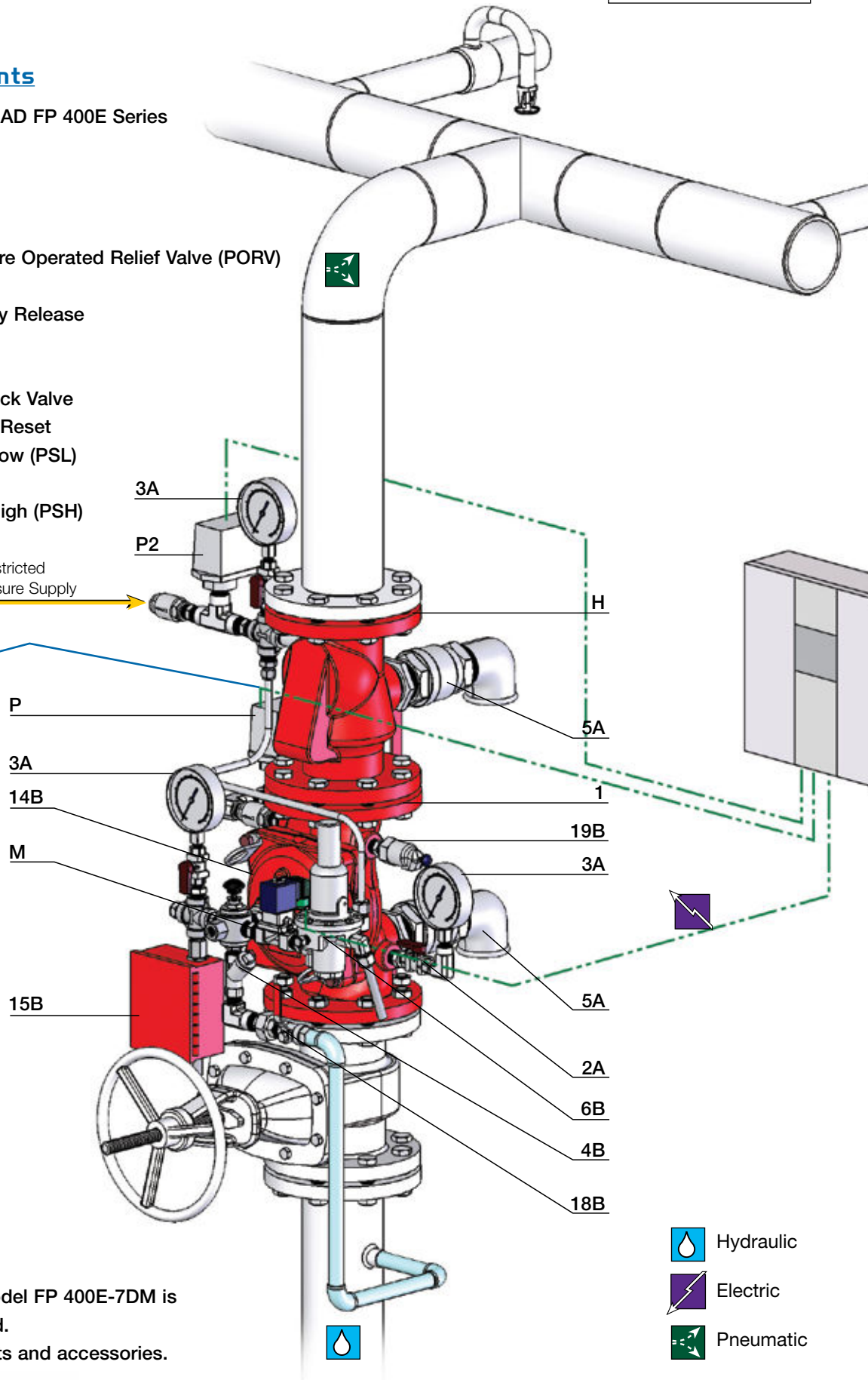

To Water
Motor Alarm





UL Listed

The BERMAD Model Model FP 400E-7DM is UL-Listed when installed with specific components and accessories.

-  Hydraulic
-  Electric
-  Pneumatic

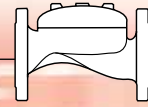
BERMAD Fire Protection



Model: FP 400E-7DM

400 Series

Technical Data

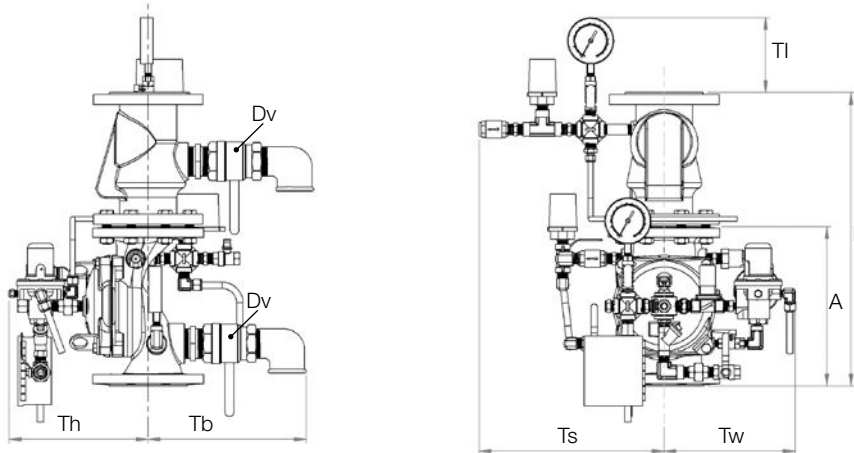

Size	2"		3"		4"		6"		8"		
	mm	inch	mm	inch	mm	inch	mm	inch	mm	inch	
Dimensions	L ₁ ⁽¹⁾	377	14 ^{13/16}	450	17 ^{3/4}	536	21 ^{3/16}	720	28 ^{6/16}	865	34 ^{1/16}
	L ₄ ⁽¹⁾	377	14 ^{13/16}	443	17 ^{7/8}	536	21 ^{3/16}	720	28 ^{6/16}	N/A	34 ^{1/16}
	TI	150	5 ^{7/8}	149	5 ^{7/8}	150	5 ^{7/8}	135	5 ^{5/16}	135	5 ^{5/16}
	Tw	208	8 ^{3/16}	223	8 ^{3/4}	233	9 ^{3/16}	272	10 ^{11/16}	326	12 ^{13/16}
	Ts	363	14 ^{1/4}	367	14 ^{7/16}	371	14 ^{5/8}	398	15 ^{11/16}	428	16 ^{7/8}
	Th	205	8 ^{1/16}	241	9 ^{1/2}	261	10 ^{1/4}	336	13 ^{1/4}	407	16
	Tb	230	9 ^{1/16}	300	11 ^{13/16}	317	12 ^{1/2}	338	13 ^{5/16}	405	15 ^{15/16}
	Dv Ø	3/4"		1 1/2"		1 1/2"		2"		2"	

Notes:

1. L₁ and L₄ are for flanged ANSI #150 and ISO PN16.
2. Provide adequate space around valve for maintenance.
3. Data is for envelope dimensions, specific component positioning may vary.

Connection Standard

- Flanged: ANSI B16.42 (Ductile Iron), B16.5 (Steel & Stainless Steel), B16.24 (Bronze)
- ISO PN16
- Grooved: ANSI/AWWA C606 for 2, 3, 4, 6 & 8"

Leakage Class

- Class VI (ANSI B16.104)

Sizes

- UL-Listed for sizes 1 1/2, 2, 2 1/2, 3, 4, 6, 8 & 10"

Water Temperature

- 0.5 – 50°C (33 – 122°F)

Pressure Rating*

- Max. working pressure: 250 psi (17 bar)

* Pressure rating might be limited due to solenoid valve rating

Air Pressure Requirements

- Valve opens on pneumatic pressure drop
- PORV factory set to open: below 20 psi (1.5 bar)
- Air must be regulated and continually maintained to be 30 - 35 psi (2.1 - 2.4 bar)
- Low-pressure alarm switch is factory set to operate at 6psi (0.4 bar)

Manufacturers Standard Materials

Main valve body and cover

- Ductile Iron ASTM A-536

Main valve internals

- Stainless Steel & Elastomer

Control Trim System

- Brass control components/accessories
- Stainless Steel 316 tubing & fittings

Elastomers

- Nylon fabric reinforced polyisoprene NR

Coating

- Electrostatic Powder Coating Poleyester, Red (RAL 3002)

Optional Materials

Main valve body

- Carbon Steel ASTM A-216 WCB
- Stainless Steel 316
- Ni-Al-Bronze ASTM B-148

Control Trim

- Stainless Steel 316

Elastomers

- NBR
- EPDM

Coating

- High Build Epoxy Fusion-Bonded with UV Protection, Anti-Corrosion

Solenoid Pilot Valve

Standard model

- 2-Way Pilot Operated type
- Brass body
- Main valve closed when de-energized
- Enclosure: General purpose watertight, NEMA 4 and 4X / IP65, Class F
- Power: 24VDC, 8 watts
- UL - Listed
- **Options (see also ordering guide)**
- Hazardous locations:
 - Class I Division 1, Gr. A, B, C, D, T4 (code 7)
 - ATEX, EEx em IIC T4 (code 8)
 - ATEX, EEx d IIC T4/5 (code 9)
- Voltage: see ordering guide (voltage option table)
- Stainless steel 316 body material (code K)



bermadfire@bermad.com • www.bermad.com

The information herein is subject to change without notice. BERMAD shall not be held liable for any errors. All rights reserved. © Copyright by BERMAD. PE4PE-7DM 11